



NEW POINT OF VIEW

VISION _ QUEEN _ CHAT _ TANGRAM

biba
SALOTTI

Biba Salotti fondata nel 1980 da Francesco Miari è un'azienda italiana affermata nel settore degli imbottiti di design.

La filosofia che caratterizza l'azienda è quella dell'artigianalità made in Italy.

Ogni prodotto nasce con originalità, si sviluppa con passione e viene prodotto con standard di qualità altissimi.

Biba Salotti considera la ricerca e la sperimentazione un elemento strategico nella politica di sviluppo aziendale.

I prodotti Biba Salotti vengono realizzati nella sede aziendale situata a Parma, un'azienda che si estende su un'area di 23000 mq di cui 10000 mq sono adibiti alla produzione.

Tutti gli imbottiti vengono realizzati con materiali selezionati che garantiscono l'alta qualità, confermando Biba Salotti un marchio riconosciuto in Europa, America e Medio Oriente e Asia.

Biba Salotti was founded in 1980 by Francesco Miari. It is an Italian company, successful in the sector of soft furnishings.

The philosophy that characterises the company is craftsmanship MADE IN ITALY.

Each product is created with originality, is developed with passion and is reproduced with exceptionally high quality standards.

Biba Salotti considers research and experimentation to be a strategic element in the company's development.

Biba Salotti products are created at the company headquarters in Parma, a facility that covers an area of 23,000 square metres, 10,000 of which are used for production.

All the soft furnishings are made from selected materials that guarantee the high quality, ensuring that Biba Salotti is a brand recognised in Europe, America, Middle East and Asia.

biba
S A L O T T I

VISION

Design ed innovazione trovano una nuova forma d'espressione contemporanea; comfort ed versatilità disegnano il nuovo sorprendente progetto firmato dall'architetto Danilo Bonfanti: Vision. Un sistema di sedute capace di dare spazio al nuovo movimento relax motorizzato, brevettato Biba.

Design and innovation find a new and contemporary form of expression; comfort and versatility shape the astonishing new project by architect Danilo Bonfanti: Vision. A seating system that showcases the new motorised recliner movement patented by Biba.







L'INNOVAZIONE FUNZIONALE
DIVENTA IL PUNTO DI
CONNESSIONE TRA INDIVIDUO,
DESIGN E CONTESTO
QUOTIDIANO...ANCHE NELLA
VERSIONE PIÙ TRADIZIONALE
DI VISION.

*Functional innovation becomes the
meeting point between the individual,
design and everyday living... even in the
most traditional of Vision.*







Vision offre la possibilità di pensare al living in modo rivoluzionario, non definito e imprevedibile, sperimentando così nuovi skyline domestici. Dinamicità, componibilità e fantasia si concretizzano in un concept che riesce a dare espressione alla mutevolezza della quotidianità.

Vision is an opportunity to rethink living in an undefined, unexpected and revolutionary way, allowing us to explore new domestic horizons. Dynamism, modularity and creativity come together in a concept that expresses the changeable nature of the everyday.



FORME GEOMETRICHE,
ELEMENTI DESTRUTTURATI
E MOVIMENTO RELAX
COMPONGONO SPAZI
ORIGINALI, RAFFINATI ED
ECLETTICI.

*Geometric shapes, deconstructed elements
and relaxing movement compose spaces that
are original, sophisticated and eclectic.*



QUEEN



Design vintage, armonia e equilibrio sono caratteristiche timeless che definiscono Queen. Una poltroncina versatile ed originale, con un'estetica avvolgente e confortevole, capace di regalare nuova personalità al contesto in cui è inserita.

Vintage design, harmony and balance are the timeless characteristics that define Queen. An original and versatile easy chair with a cosy, inviting aesthetic that can lend new personality to its surroundings.





Le gambe sottili in metallo sono caratterizzate dalla doppia cromia, ricercata ed attualissima. Un comodo pouff invita a poggiare i piedi e raddoppia il relax. Lo schienale si arricchisce e aumenta il comfort grazie al poggiatesta (optional).

The slim metal legs feature an exquisite two-tone effect, perfectly on-trend. A comfortable pouf invites you to rest your feet and redoubles relaxation. The backrest is improved for even greater comfort, thanks to the optional headrest.



CHAT

Energia, entusiasmo e sorprendente versatilità disegnano il carattere assolutamente originale di Chat. L'estrema componibilità offre la possibilità infinita di creare una zona relax unica, perfettamente integrata nell'architettura dello spazio abitativo.

Energy, enthusiasm and extraordinary versatility characterise the unique personality of Chat. Extreme modularity offers limitless possibilities to create an original relaxation area, perfectly in line with the architecture of your home.





Le sedute in diverse misure si accostano creando isole relax e ampie zone conversazione. Chat è un progetto che nasce dall'esigenza quotidiana dell'individuo di incontrarsi, confrontarsi e rilassarsi in spazi informali, dinamici e non convenzionali.



Seats of different sizes come together to create islands of relaxation and ample scope for conviviality. The Chat project arises from the individual's daily need to gather, converse and relax in spaces that are informal, dynamic and unconventional.







Il gioco diventa parte integrante dell'estetica del sistema di sedute Chat. L'elemento curvo permette di creare composizioni avvolgenti, originali e sofisticate adatte a spazi domestici e perfette per ambienti contract. Armonia ed equilibrio esaltano la bellezza geometrica del design e delle scelte cromatiche.

Play becomes an integral part of aesthetics in the Chat seating system. The curvaceous unit allows the creation of inviting, original and sophisticated arrangements that are ideal for the home and perfect for contract environments. Harmony and balance accentuate the geometric beauty of design and colour schemes.





SITTING SYSTEM



TANGRAM + SILVER LIGHT



Vivere in puro stile libero, senza limiti di immaginazione. Lo spazio abitativo diventa nostro con forme e dimensioni che lasciano spazio alla creatività. Tangram, sitting system comprende ampie panche in diverse misure e forme. Nuove sedute da accostare e "vestire" con coerenza oppure con originalità, assecondando la propria identità.

A pure and free lifestyle with no limits to the imagination. The living space becomes ours with shapes and sizes that leave plenty of room for creativity.

The Tangram seating system includes generous benches in several shapes and sizes. New seats to combine and dress in tune with their surroundings or in new and original ways to express your identity.



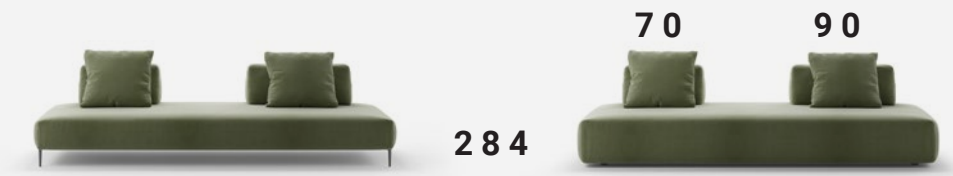



TANGRAM CI LIBERA DA
SCHEMI PRECISI PER
LASCIARE SPAZIO AL
NOSTRO STILE.

*Tangram frees us from precise schemes,
leaving space for our own personal style.*





CHAT

Pagina 20

Design:
Danilo Bonfanti

STRUTTURA

Struttura in legno e multistrato.

MOLLEGGIO

Molleggio della seduta in nastri elastici intrecciati ad alta densità.

SEDUTA

Cuscini di seduta in poliuretano densità 35 ecoelast rivestiti da una falda Dacron.

SCHIENALE

Cuscini schienale 40% poliuretano - 40% cin fill ball (fibra poliestere siliconata cava a pallino) - 20% memory foam, a camere separate orizzontalmente interamente rivestiti da una tela in cotone 100%

GUANCIALI

Guanciali misto-piuma naturale lavata, depolverizzata e sterilizzata. Misura dei guanciali 50x50 cm.

STRUCTURE

Laminated wood structure.

SUSPENSION

The seat suspension system uses high-density intertwined elastic bands.

SEAT

Polyurethane padding seat cushions 35 ecoelast covered in a layer of Dacron.

BACKREST

Backrest cushions 40% Polyurethane - 40% Cin Fill Ball (silicone-coated hollow polyester fibre pellets) - 20% Memory Foam arranged in separate horizontal chambers, 100% cotton fabric cover.

PILLOW

Mixed natural dust-free, washed and sterilized down pillows. Pillow size 50x50 cm.

ELEMENTI DX-SX / RT-LT Elements

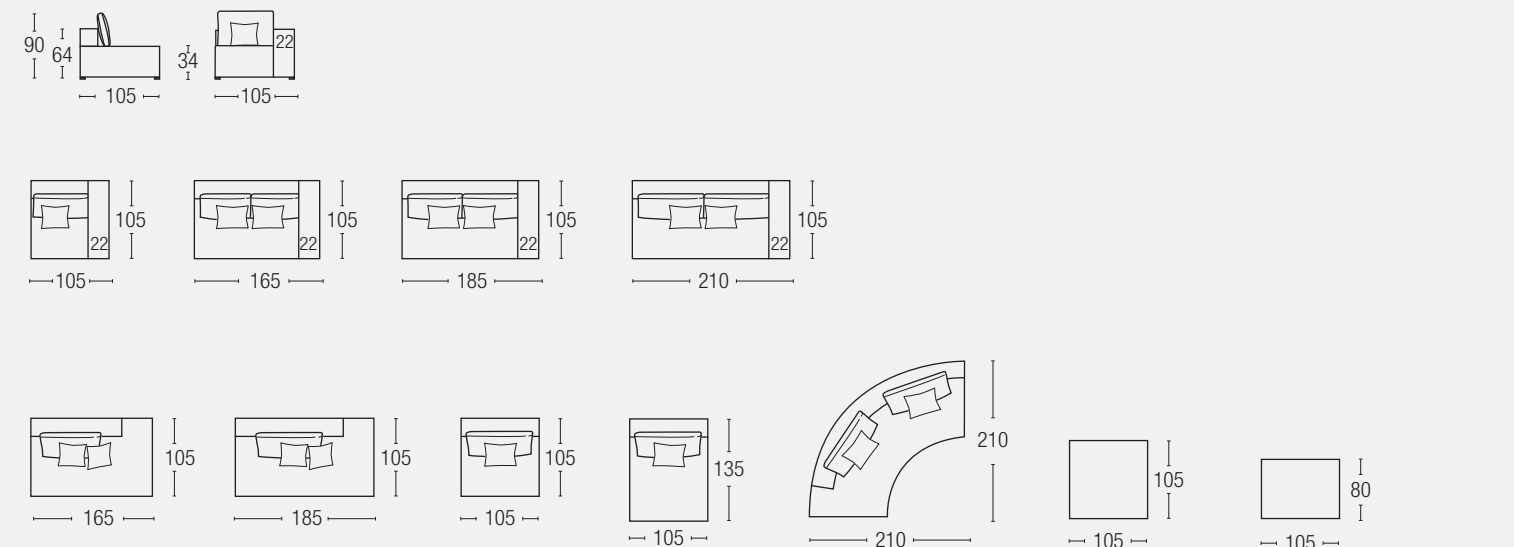

ESEMPI DI CONFIGURAZIONI CONFIGURATIONS EXAMPLES

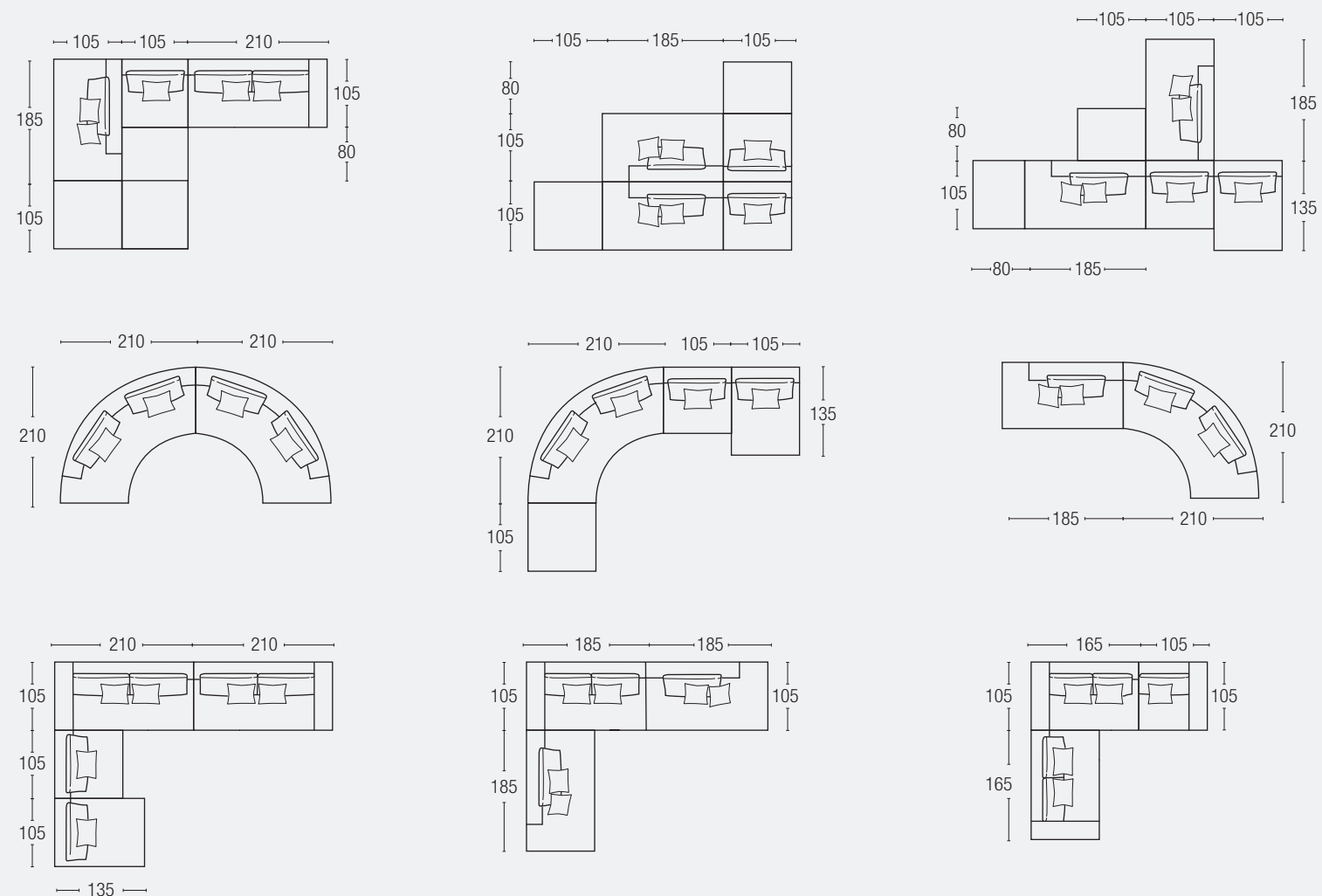

PIEDINI / FOOT

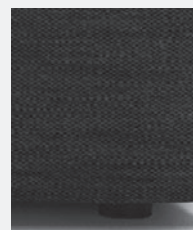

H. 4 cm



QUEEN

Pagina 16

Design:
Danilo Bonfanti

STRUTTURA

Struttura in legno e multistrato imbottita in poliuretano a quote differenziate e rivestita in resinato accoppiato dello spessore di 10 mm.

MOLLEGGIO

Molleggio della seduta in nastri elastici intrecciati ad alta densità.

STRUCTURE

Laminated wood structure padded with polyurethane foam of different densities and covered in a 10 mm layer of bonded resin.

SUSPENSION

The seat suspension system uses high-density intertwined elastic bands.

SEDUTA

Cuscini di seduta in poliuretano densità 35 ecoelast, rivestiti da una falda Dacron.

SEAT

Polyurethane padding seat cushions 35 ecoelast density, covered in a layer of Dacron.

PIEDINO / FOOT



Base metallo, Manganese o Bronzato.

Metal base, manganese or bronze.

A richiesta: RAL verniciato opaco con possibilità di personalizzazione dei puntali (maggiorazione prezzo).

On request: Matt RAL varnished with possibility of customization the feet tips (price increase)

POLTRONA/ARMCHAIR

POUF

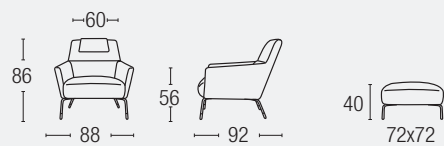

TANGRAM

Pagina 32

Design:
Danilo Bonfanti

STRUTTURA

Struttura in legno e multistrato.

CUSCINI

Cuscini schienale cm 60x60 con fascia: 50% in piuma naturale depolverizzata, lavata e sterilizzata - 50% cin fill ball (fibra poliestere siliconata cava a pallino).

STRUCTURE

Laminated wood structure.

SUSPENSION

The seat suspension system uses high-density intertwined elastic bands.

BACKREST AND ARMREST

Backrest cushions with band 60x60cm: 50% natural dust-free, washed and sterilized Down padding - 50% Cin Fill Ball (silicone-coated hollow polyester fibre pellets).

MOLLEGGIO

Molleggio della seduta in nastri elastici intrecciati ad alta densità.

SEDUTA E SCHIENALE con peso

In poliuretano densità 35 ecoelast, rivestiti da una falda Dacron.

SEAT AND BACKREST with weight

Polyurethane padding 35 ecoelast density covered in a layer of Dacron.

PIEDINO ALTO/ HIGH FOOT

(con/with Silver-Nick-Bravo e Wind)



PIEDINO ALTO/ HIGH FOOT

(con/with Silver-Nick-Bravo e Wind)



SPILLO NICK / SPILLO NICK FOOT

Manganese / Manganese
Cromato lucido / Polished chromed
Satinato / Satin

h. 15 cm

A richiesta / On request:

- RAL verniciato opaco (maggiorazione prezzo)
Matt RAL varnished (price increase)

PONTE NICK / PONTE NICK FOOT

Manganese / Manganese
Cromato lucido / Polished chromed
Satinato / Satin

h. 15 cm

A richiesta / On request:

- Montaggio a 45°/45° angle installation
- RAL verniciato opaco (maggiorazione prezzo)
Matt RAL varnished (price increase)

PIEDINO BASSO / LOW FOOT

(con/with Zeno-Plano)

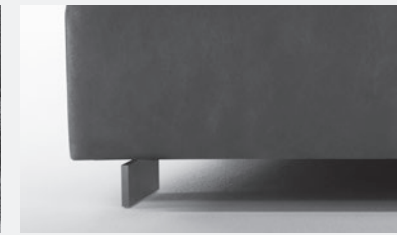

PIEDINO BASSO / LOW FOOT

(con/with Zeno-Plano)



LAMINA ZENO/ ZENO LAMINA FOOT

Manganese / Manganese
Satinato / Satin

h.7,5 cm

A richiesta / On request: h.9,5cm

BISCOTTO / BISCOTTO FOOT

In legno, frontale rivestito in metallo cromato lucido
Wood foot with front covered in polished chromed metal

h. 7,5 cm

A richiesta / On request: h. 9,5 cm

DIVANO ALTO / HIGH SOFA

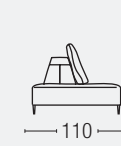

DIVANO BASSO / LOW SOFA



SCHIENALE / BACKREST

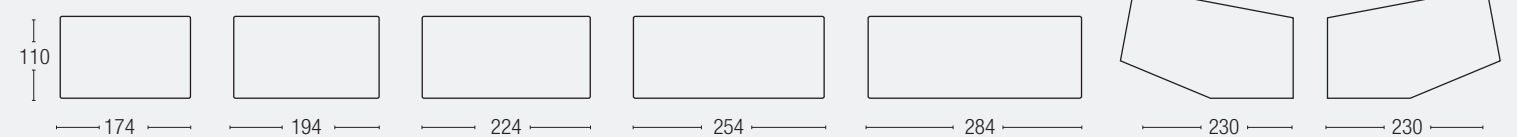
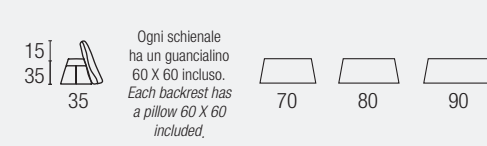



VISION

Pagina 02

Design:
Danilo Bonfanti

STRUTTURA

Struttura in legno e multistrato imbottita in poliuretano a quote differenziate e rivestita in resinato accoppiato dello spessore di 10 mm.

MOLLEGGIO

Molleggio della seduta in nastri elastici intrecciati ad alta densità.

SEDUTA

Cuscini di seduta in poliuretano densità 35 ecoelast, interamente rivestiti da una falda in dacron.

SCHIENALE

Cuscini schienale 50% in piuma naturale depolverizzata, lavata e sterilizzata, a camere separate orizzontalmente, e 50% poliuretano; interamente rivestiti da una tela in cotone 100%.

GUANCIALI

Guanciali misto piuma naturale lavata, depolverizzata e sterilizzata. Misura dei guanciali 50x50 cm e 60x60 cm con fascia.

STRUCTURE

Laminated wood structure padded with polyurethane foam of different densities and covered in a 10 mm layer of bonded resin.

SUSPENSION

The seat suspension system uses high-density intertwined elastic bands.

SEAT

Polyurethane padding seat cushions ecoelast 35 density, covered in a layer of Dacron.

BACKREST

Backrest cushions 50% natural dust-free, washed and sterilized down padding arranged in separate horizontal chambers and 50% polyurethane, 100% cotton fabric cover.

PILLOW

Mixed natural dust-free, washed and sterilized down pillows. Pillow size 50x50 cm and 60x60 cm with band.

RELAX Brevettato / Patented

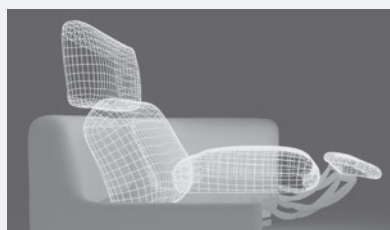

guarda il video
see more

Esclusivo Movimento Relax motorizzato con telecomando wireless

Patented Recliner System with wireless remote control.

PIEDINI / FOOT

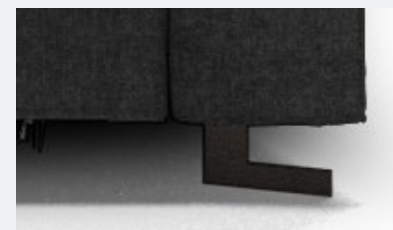

PIEDE LAMINA / LAMINA FOOT

Manganese / manganese
Bronzato / Bronzed
h 10 cm
A richiesta / on request
RAL verniciato opaco
(maggiorazione prezzo)
Matt RAL varnished
(price increase)

DIVANO / Sofa

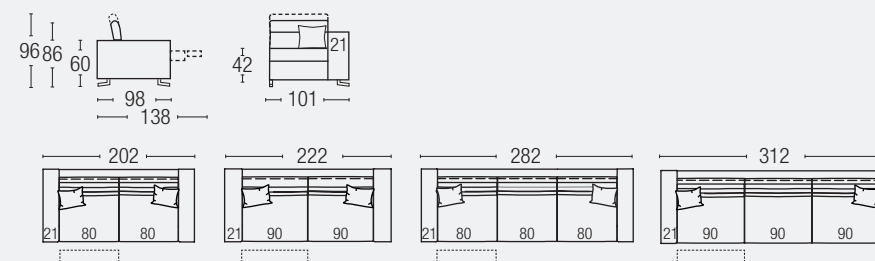

Il sistema relax è disponibile sulle sedute con bracciolo
Recliner System is available for each seat with arm

ELEMENTO CENTRALE / CENTRAL UNIT

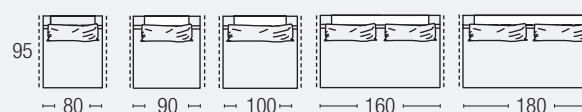

CHAISE LONGUE DX-SX

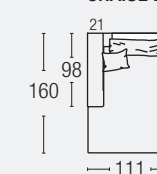

ISOLA SPECIALE DX-SX / SPECIAL ISLE RT-LT

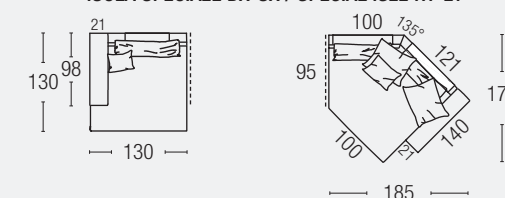

PANCA / BENCH

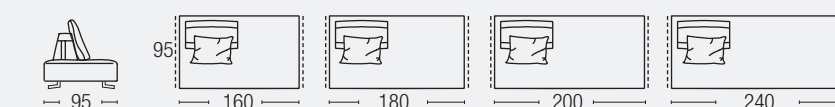

ELEMENTO SPECIALE PANCHE DX-SX / RT-LT SPECIAL BENCH

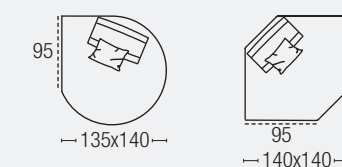

Schienali d'appoggio a richiesta
Backrest on request

TERMINALE RELAX DX-SX / ARMREST UNIT RELAX RT-LT

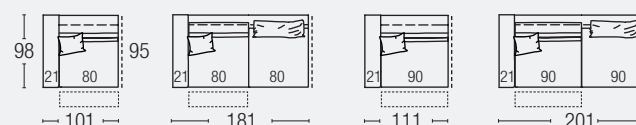

TERMINALE FISSO DX-SX / RT-LT ARMREST UNIT

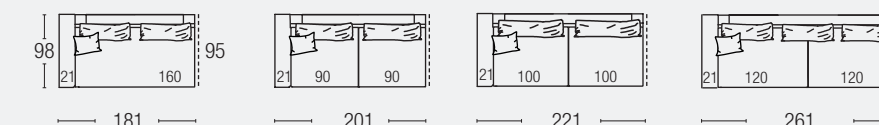

ELEMENTO CON POUF DX-SX / RT-LT ELEMENT UNIT WITH POUF

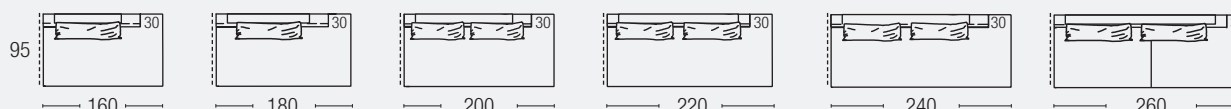

ANGOLARE CON POUF DX-SX / RT-LT CORNER WITH POUF

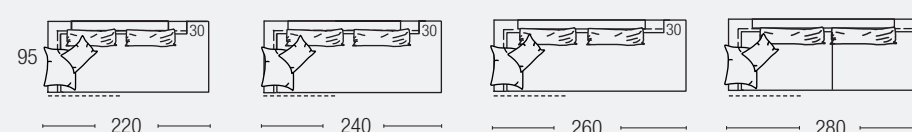

TERMINALE ANGOLARE DX-SX / RT-LT CORNER ARMREST

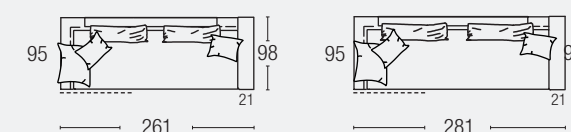

ANGOLARE DX-SX / RT-LT CORNER

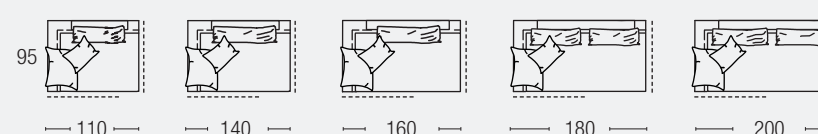

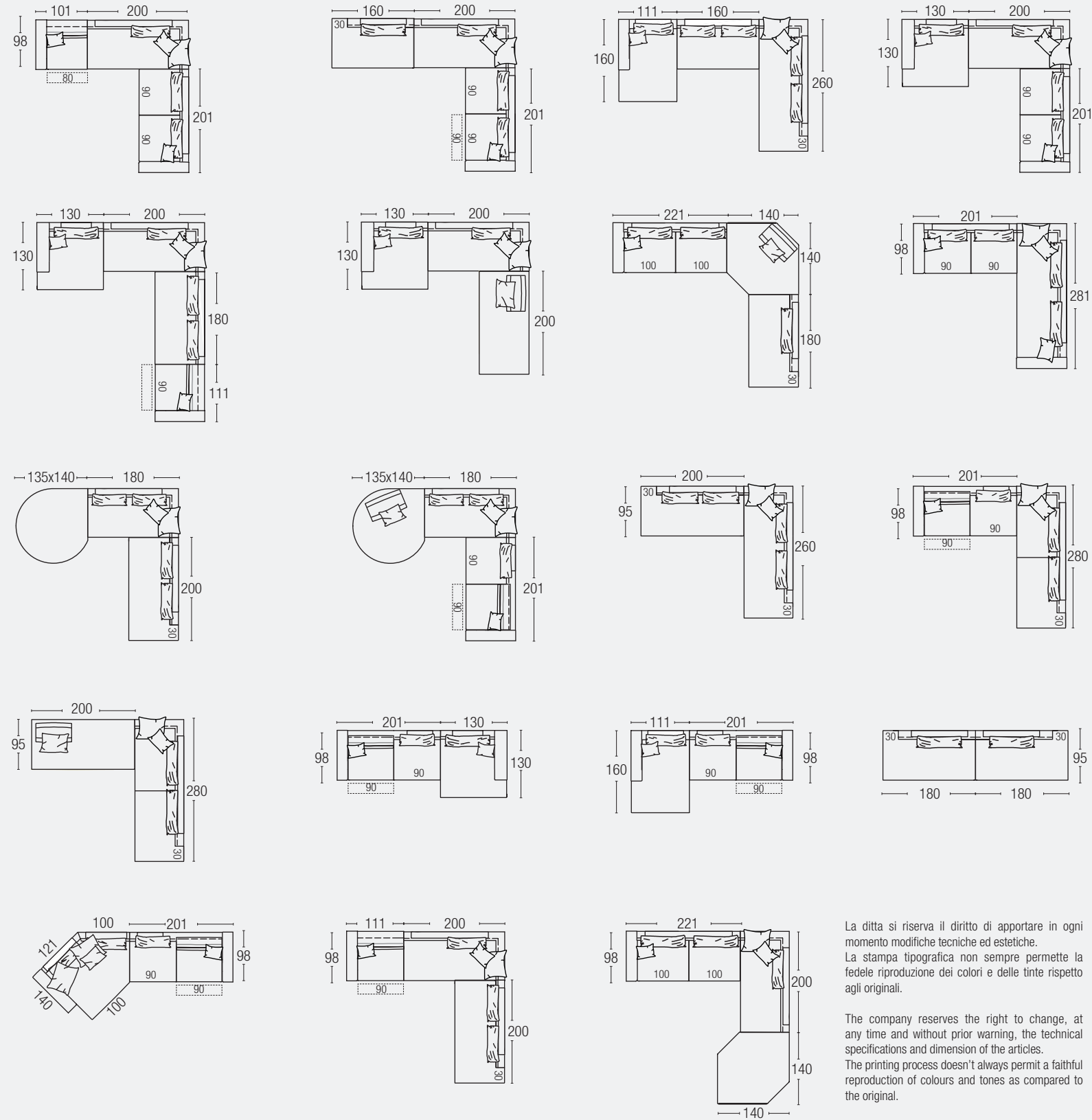

La ditta si riserva il diritto di apportare in ogni momento modifiche tecniche ed estetiche.
 La stampa tipografica non sempre permette la fedele riproduzione dei colori e delle tinte rispetto agli originali.

The company reserves the right to change, at any time and without prior warning, the technical specifications and dimension of the articles.
 The printing process doesn't always permit a faithful reproduction of colours and tones as compared to the original.

AD: arch. Danilo Bonfanti
 LAYOUT E IMMAGINI: Studio Target - Lazzate (MB)
 STYLING: Roberta Mari
 Sculture: Carlo Guzzi

biba
S A L O T T I



www.bibasalotti.it

BIBA SALOTTI s.r.l.: Via Spezia, 187- 43126 Parma - Italy - Tel. +39 0521.293002 - Fax +39 0521.292921 - sales@bibasalotti.com